

Produit #	Unité extérieure		GUD36W/A-D(U)		GUD60W/A-D(U)	
	Unité Intérieure		GUD24AH2/A-D(U)	GUD36AH2/A-D(U)	GUD48AH2/A-D(U)	GUD60AH2/A-D(U)
Qté						
PERFORMANCE TECHNIQUE						
Tension		V / Ph / Hz	208-230 / 1 / 60			
Capacité en climatisation	Nominale	BTU/hr	24000	36000	48000	54000
	Min. – max.	W (BTU/hr)	3517 - 7034 (12000 - 24000)	5275 - 10844 (18000 - 37000)	9964 - 14067 (34000 - 48000)	10257 - 15826 (35000 - 54000)
Capacité en chauffage	Nominale	BTU/hr	24000	36000	48000	54000
	Min. – max.	W (BTU/hr)	3517 - 8792 (12000-30000)	5275 - 11137 (18000-38000)	9964 - 15240 (34000 - 52000)	10257 - 17584 (35000 - 60000)
TRÈS2 (SEER2)		-	17	16	17	16
CPSC2 (HSPF2)		-	9	9	9	9
TRÈ2 (EER2)		-	12	10	11	10
COP à -15°C (5°F)		W/W	1.8	1.8	1.8	1.8
COP à 8°C (47°F)		W/W	4	3	3.3	3.5
Certification AHRI		-	206249116	206249117	206249119	206249118
ENERGY STAR		-	✓	-	-	-
UNITÉ INTÉRIEURE						
Déshumidification		pt/hr (l/hr)	3.06 (1.45)	9.70 (4.60)	9.94 (4.70)	12.13 (5.74)
Débit d'air volumique		PCM	940	1000	1470	1600
Niveau de Pression Sonore		dB (A)	45	47	50	51
MCA (Intensité minimum)		A	4	4	8	8
MOCP (Disjoncteur/fusible max.)		A	15	15	15	15
Dimensions Externes (L x H x I)		po (mm)	21-1/4 x 48-1/4 x 21-1/4 (540 x 1225 x 540)	21-1/4 x 48-1/4 x 21-1/4 (540 x 1225 x 540)	24-3/4 x 57 x 21-1/4 (630 x 1450 x 540)	24-3/4 x 57 x 21-1/4 (630 x 1450 x 540)
Dimensions Emballage (L x H x I)		po (mm)	26 x 50-7/16 x 23-3/4 (660 x 1280 x 605)	26 x 50-7/16 x 23-3/4 (660 x 1280 x 605)	27-5/16 x 59-3/8 x 26 (695 x 1510 x 660)	27-5/16 x 59-3/8 x 26 (695 x 1510 x 660)
Poids Net		lb (kg)	156 (71)	156 (71)	202 (92)	202 (92)
Poids Brut		lb (kg)	169 (77)	169 (77)	218 (99)	218 (99)
UNITÉ EXTÉRIEURE						
Niveau de Pression Sonore		dB (A)	55 (45 - 56)	57 (45 - 57)	58 (48 - 61)	58 (48 - 61)
MCA (Intensité minimum)		A	24	24	35	35
MOCP (Disjoncteur/fusible max.)		A	35	35	45	45
Puissance du moteur du ventilateur		A	1.5	1.5	1.5 x 2	1.5 x 2
Volume Réfrigérant (R410A)		kg (oz)	4.2 (148)	4.2 (148)	6.2 (220.5)	6.2 (220.5)
Température ambiante de fonctionnement	Climatisation	°F (°C)	5 à 129 (-15 à 54)			
	Chauffage	°F (°C)	-22 à 75 (-30 à 24)			
Dimensions Externes (W x H x D)		po (mm)	37 x 32-1/4 x 18-1/8 (940 x 820 x 460)	37 x 32-1/4 x 18-1/8 (940 x 820 x 460)	39-3/8 x 53-5/8 x 14-1/2 (1000 x 1365 x 368)	39-3/8 x 53-5/8 x 14-1/2 (1000 x 1365 x 368)
Dimensions Emballage (W x H x D)		po (mm)	42-11/16 x 38-3/8 x 22-9/16 (1085 x 975 x 575)	42-11/16 x 38-3/8 x 22-9/16 (1085 x 975 x 575)	45-7/16 x 59-1/4 x 19-7/16 (1154 x 1505 x 494)	45-7/16 x 59-1/4 x 19-7/16 (1154 x 1505 x 494)
Poids Net		lb (kg)	217 (98.5)	217 (98.5)	308 (140)	308 (140)
Poids Brut		lb (kg)	240 (109)	240 (109)	337 (153)	337 (153)
TUYAUTERIE DE RACCORDEMENT / RÉFRIGÉRANT						
Volume additionnel de réfrigérant		oz/pi (g/m)	0.32 (29)	0.32 (29)	0.32 (29)	0.32 (29)
Connexion pipes outer diameter	Liquid	po	3/8	3/8	3/8	3/8
	Gas	po	3/4	3/4	3/4	3/4
Longueur de préchargement		pi. (m)	31 (9.5)	31 (9.5)	31 (9.5)	31 (9.5)
Longueur maximale entre les unités intérieure et extérieure		pi (m)	164 (50)	164 (50)	100 (30)	100 (30)
Hauteur maximale entre les unités intérieure et extérieure		pi (m)	100 (30)	100 (30)	50 (15)	50 (15)

Unité Extérieure

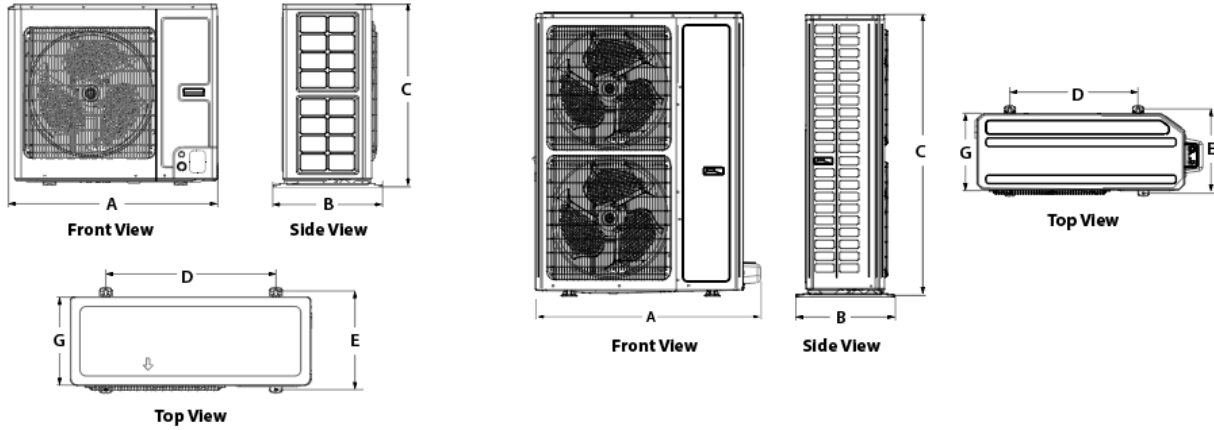

Unité Extérieure	A		B		C		D		E		G	
	po	mm	po	mm	po	mm	po	mm	po	mm	po	mm
GUD36W/A-D(U)	37	940	20 1/8	510	32 1/4	820	24	610	19 1/8	485	18 1/8	460
GUD60W/A-D(U)	42 3/4	1085	16 7/8	430	53 3/4	1365	24 3/8	620	15 5/8	400	14 1/2	370

Unité Intérieure: Cabinet Souffleur

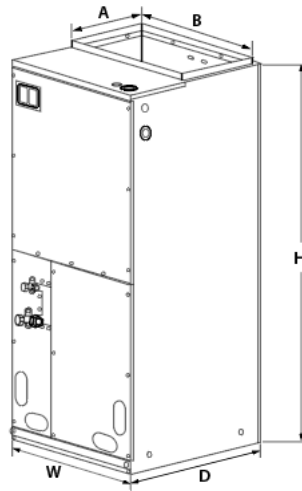

Cabinet Souffleur	W		D		H		A		B	
	po	mm	po	mm	po	mm	po	mm	po	mm
GUD24AH2/A-D(U)	21 1/4	540	21 1/4	540	48 1/4	1225	11 5/8	295	20	508
GUD36AH2/A-D(U)										
GUD48AH2/A-D(U)	24 3/4	630	21 1/4	540	57	1448	11 5/8	295	20	508
GUD60AH2/A-D(U)										

Cabinet Souffleur GUD24AH2/A-D(U) + Compresseur GUD36W/A-D(U)

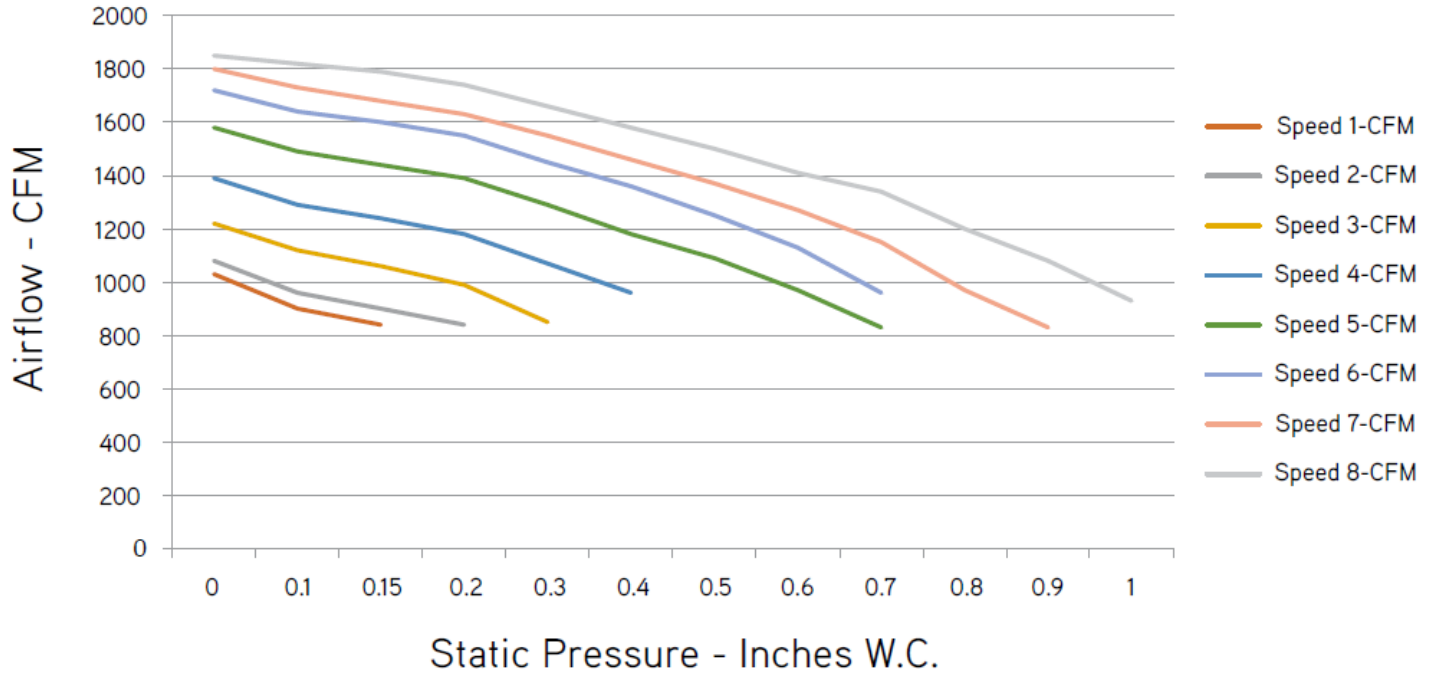

STATIC PRESSURE Inches W.C.	0	0.1	0.15	0.2	0.3	0.4	0.5	0.6	0.7	0.8	0.9	1.0
Speed 1 - CFM	1030	900	840									
Speed 2 - CFM	1080	960	900	840								
Speed 3 - CFM	1220	1120	1060	990	850							
Speed 4 - CFM	1390	1290	1240	1180	1070	960						
Speed 5 - CFM	1580	1490	1440	1390	1290	1180	1090	970	830			
Speed 6 - CFM	1720	1640	1600	1550	1450	1360	1250	1130	960			
Speed 7 - CFM	1800	1730	1680	1630	1550	1460	1370	1270	1150	970	830	
Speed 8 - CFM	1850	1820	1790	1740	1660	1580	1500	1410	1340	1200	1080	930

Cabinet Souffleur GUD36AH2/A-D(U) + Compresseur GUD36W/A-D(U)

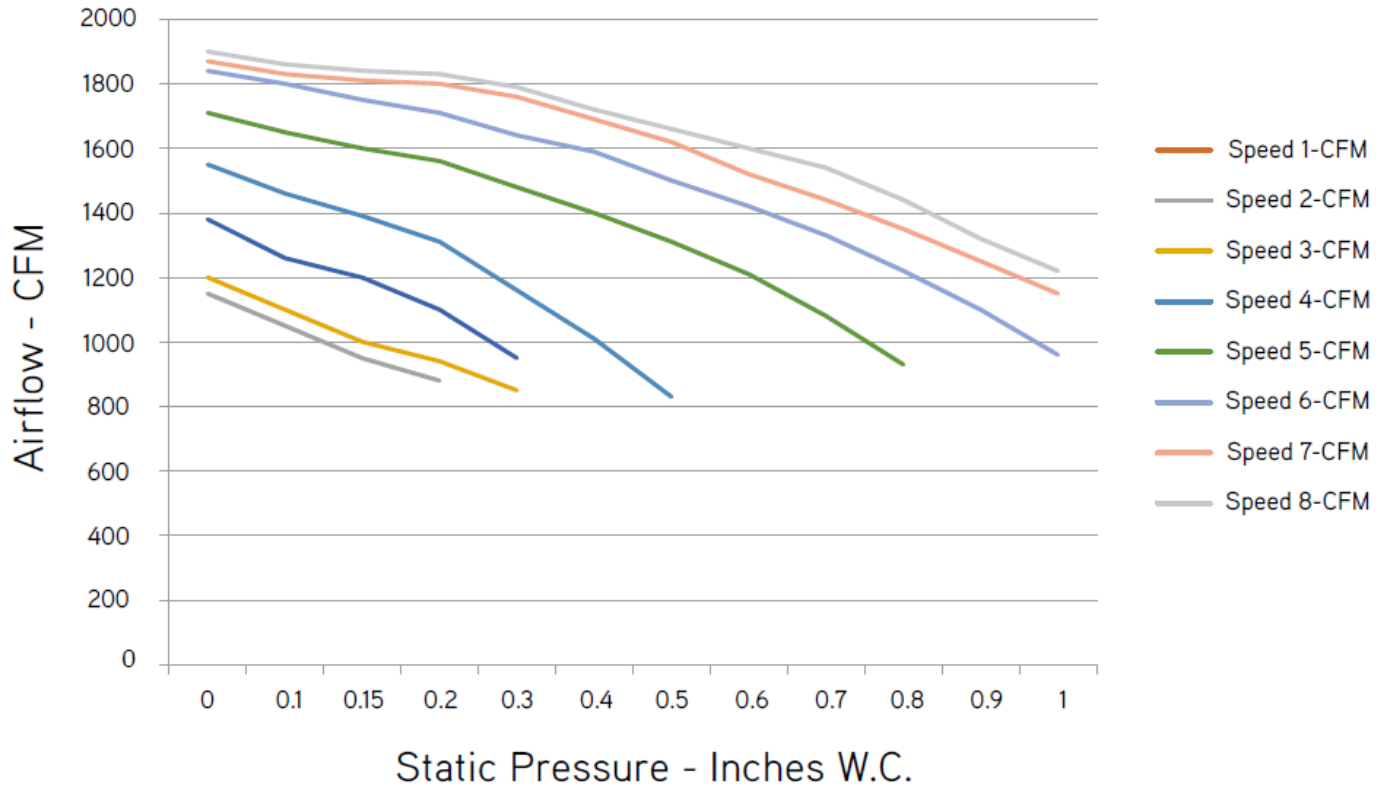

STATIC PRESSURE Inches W.C.	0	0.1	0.15	0.2	0.3	0.4	0.5	0.6	0.7	0.8	0.9	1.0
Speed 1 - CFM	1150	1050	950	880								
Speed 2 - CFM	1200	1100	1000	940	850							
Speed 3 - CFM	1380	1260	1200	1100	950							
Speed 4 - CFM	1550	1460	1390	1310	1160	1010	830					
Speed 5 - CFM	1710	1650	1600	1560	1480	1400	1310	1210	1080	930		
Speed 6 - CFM	1840	1800	1750	1710	1640	1590	1500	1420	1330	1220	1100	960
Speed 7 - CFM	1870	1830	1810	1800	1760	1690	1620	1520	1440	1350	1250	1150
Speed 8 - CFM	1900	1860	1840	1830	1790	1720	1660	1600	1540	1440	1320	1220

Cabinet souffleur GUD48AH2/A-D(U) + Compresseur GUD60W/A-D(U)

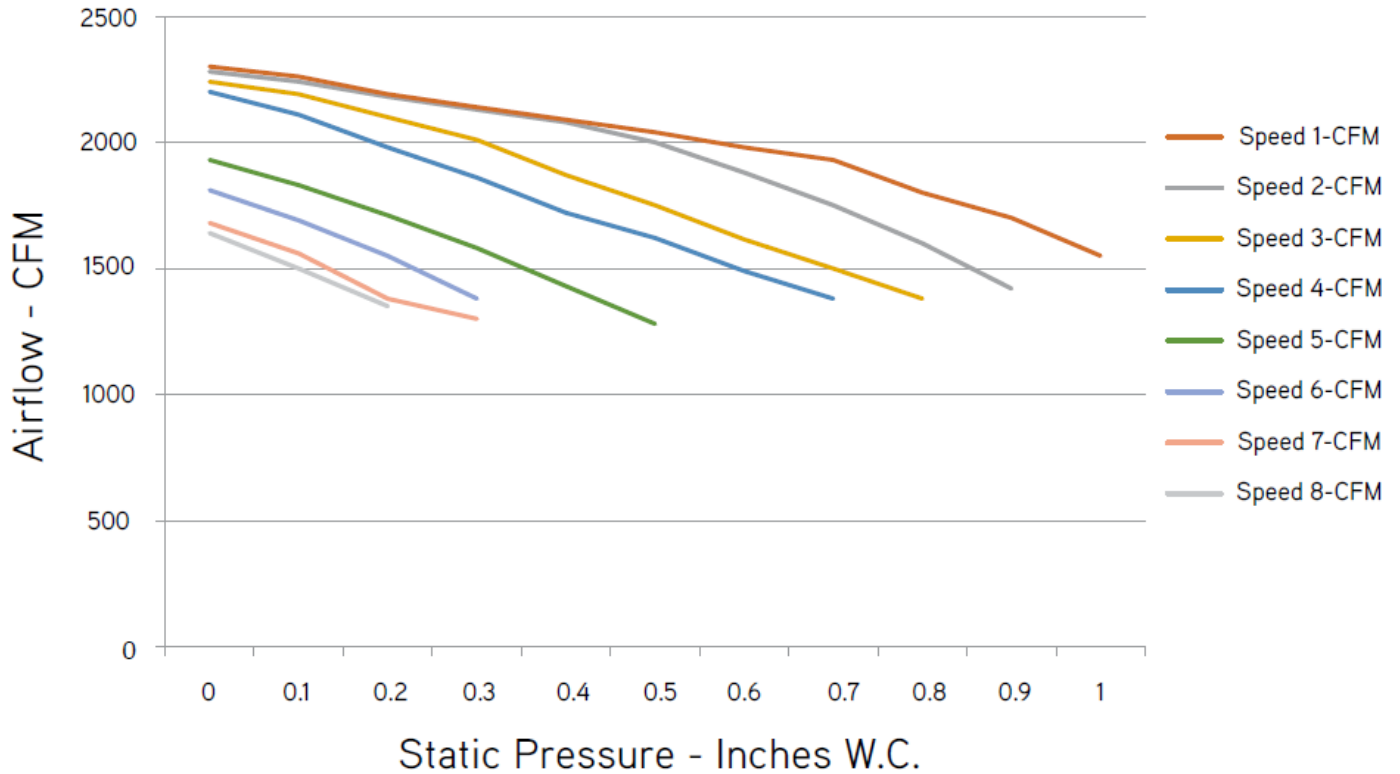

STATIC PRESSURE Inches W.C.	0	0.1	0.15	0.2	0.3	0.4	0.5	0.6	0.7	0.8	0.9	1.0
Speed 1 - CFM	1640	1500	1450	1350								
Speed 2 - CFM	1680	1560	1500	1380	1300							
Speed 3 - CFM	1810	1690	1620	1550	1380							
Speed 4 - CFM	1930	1830	1770	1710	1580	1430	1280					
Speed 5 - CFM	2200	2110	2040	1980	1860	1720	1620	1490	1380			
Speed 6 - CFM	2240	2190	2145	2100	2010	1870	1750	1615	1500	1380		
Speed 7 - CFM	2280	2240	2200	2180	2130	2080	2000	1880	1750	1600	1420	1150
Speed 8 - CFM	2300	2260	2220	2190	2140	2090	2040	1980	1930	1800	1700	1550

Cabinet souffleur GUD60AH2/A-D(U) + Compresseur GUD60W/A-D(U)

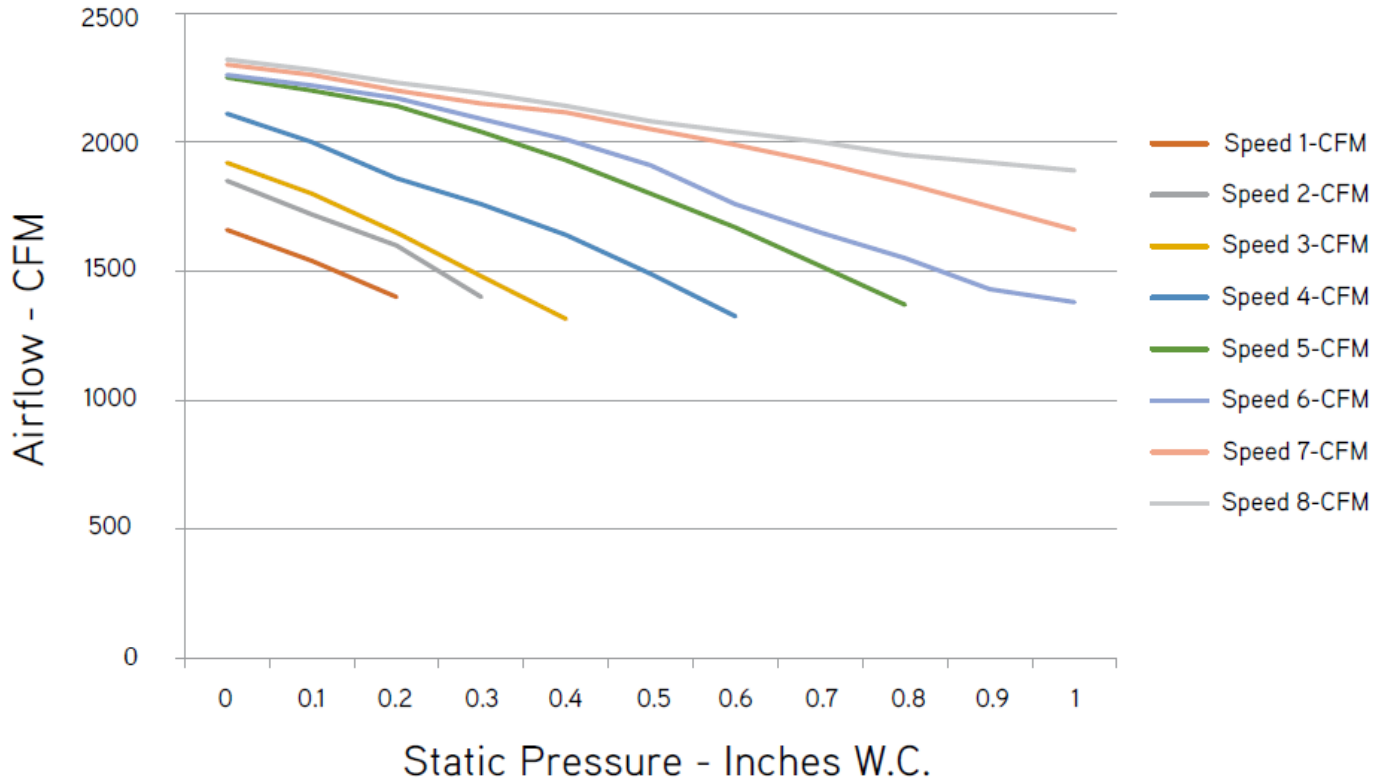

STATIC PRESSURE Inches W.C.	0	0.1	0.15	0.2	0.3	0.4	0.5	0.6	0.7	0.8	0.9	1.0
Speed 1 - CFM	1660	1540	1470	1400								
Speed 2 - CFM	1850	1720	1650	1600	1400							
Speed 3 - CFM	1920	1800	1730	1650	1480	1315						
Speed 4 - CFM	2110	2000	1950	1860	1760	1640	1490	1325				
Speed 5 - CFM	2250	2200	2190	2140	2040	1930	1800	1670	1520	1370		
Speed 6 - CFM	2260	2220	2200	2170	2090	2010	1910	1760	1650	1550	1430	1380
Speed 7 - CFM	2300	2260	2230	2200	2150	2115	2050	1990	1920	1840	1750	1660
Speed 8 - CFM	2320	2280	2250	2230	2190	2140	2080	2040	2000	1950	1920	1890

UNITÉ EXTÉRIEURE GUD AVEC SERPENTIN EN A GCAT

X60059A

PRODUIT #	Unité Intérieure	GCAT24F/NAA	GCAT36F/NAA	GCAT48H/NAA	GCAT60H/NAA	
	Unité Extérieure	GUD36W/A-D(U)		GUD60W/A-D(U)		
PERFORMANCE TECHNIQUE						
Tension	V / Ph / Hz	208-230 / 1 / 60				
Capacité en climatisation	Nominale	W (BTU/hr)	24000	36000	48000	54000
	Min. – max.	W (BTU/hr)	3517 - 7034 (12000 - 24000)	5275 - 10844 (18000 - 37000)	9964 - 14067 (34000 - 48000)	10257 - 15826 (35000 - 54000)
Capacité en chauffage	Nominale	W (BTU/hr)	24000	36000	48000	54000
	Min. – max.	W (BTU/hr)	3517 - 8792 (12000-30000)	5275 - 11137 (18000-38000)	9964 - 15240 (34000 - 52000)	10257 - 17584 (35000 - 60000)
TRÉS2 (SEER2)	-	15.2	15.2	15.2	15.2	
CPSC2 (HSPF2)	-	8.5	8.5	8.5	8.5	
TRÉ2 (EER2)	W/W	11	9.5	10	9.5	
COP à -15°C (5°F)	W/W	1.8	1.8	1.8	1.8	
COP à 8°C (47°F)	W/W	4.2	3.5	3.6	3.5	
Certification AHRI	-	211644150	211644151	211644152	211644153	
ENERGY STAR	-	YES	NO	NO	NO	
UNITÉ INTÉRIEURE						
Déshumidification	L/hr (pt/hr)	2.85 (6.03)	4.58 (9.68)	4.70 (9.94)	5.74 (12.13)	
Débit d'air volumique (Max.)	CFM	800	1000	1230	1510	
Dimensions Externes (L x H x I)	po (mm)	17-1/2 x 23 x 21-1/4 (445 x 585 x 540)	17-1/2 x 23 x 21-1/4 (445 x 585 x 540)	24-1/2 x 28-1/2 x 21-1/4 (622 x 725 x 540)	24-1/2 x 28-1/2 x 21-1/4 (622 x 725 x 540)	
Dimensions Emballage (L x H x I)	po (mm)	21 x 25-13/16 x 27-1/8 (535 x 655 x 690)	21 x 25-13/16 x 27-1/8 (535 x 655 x 690)	28-1/8 x 31-5/16 x 27-1/8 (714 x 795 x 689)	28-1/8 x 31-5/16 x 27-1/8 (714 x 795 x 689)	
Charge de réfrigérant	oz	8.8	8.8	8.8	8.8	
Poids Net	lb (kg)	64 (29)	64 (29)	95 (43)	95 (43)	
Poids Brut	lb (kg)	75 (34)	75 (34)	110 (50)	110 (50)	
UNITÉ EXTÉRIEURE						
Niveau de Pression Sonore	dB (A)	55 (45 – 56)	57 (45 - 57)	58 (48 - 61)	58 (48 - 61)	
MCA (intensité minimum)	A	24	24	35	35	
MOCP (Disjoncteur/fusible max.)	A	35	35	45	45	
Puissance du moteur du ventilateur	W	1.5	1.5	1.5 x 2	1.5 x 2	
Volume Réfrigérant (R410A)	oz (kg)	148 (4.2)	148 (4.2)	220.5 (6.2)	220.5 (6.2)	
Température ambiante de fonctionnement	Climatisation	°F (°C) 5 to 129 (-15 to 54)				
	Chauffage	°F (°C) -22 to 75 (-30 to 24)				
Dimensions Externes (L x H x I)	po (mm)	37 x 32-1/4 x 18-1/8 (945 x 820 x 460)	37 x 32-1/4 x 18-1/8 (945 x 820 x 460)	39-3/8 x 53-5/8 x 14-1/2 (1000 x 1365 x 368)	39-3/8 x 53-5/8 x 14-1/2 (1000 x 1365 x 368)	
Dimensions Emballage (L x H x I)	po (mm)	42-11/16 x 38-3/8 x 22-9/16 (1085 x 975 x 575)	42-11/16 x 38-3/8 x 22-9/16 (1085 x 975 x 575)	45-7/16 x 59-1/4 x 19-7/16 (1154 x 1505 x 494)	45-7/16 x 59-1/4 x 19-7/16 (1154 x 1505 x 494)	
Poids Net	lb (kg)	217 (98)	217 (98)	308 (140)	308 (140)	
Poids Brut	lb (kg)	240 (109)	240 (109)	337 (153)	337 (153)	
TUYAUTÉRIE DE RACCORDEMENT / RÉFRIGÉRANT						
Longueur de préchargement	pi (m)	31 (9.5)	31 (9.5)	31 (9.5)	31 (9.5)	
Volume additionnel de réfrigérant	oz/pi (g/m)	0.32 (29)	0.32 (29)	0.32 (29)	0.32 (29)	
Diamètre externe tuyau liquide	po	3/8	3/8	3/8	3/8	
Diamètre externe tuyau gaz	po	3/4	3/4	3/4	3/4	
Longueur maximale entre les unités intérieure et extérieure	pi (m)	164 (50)	164 (50)	164 (50)	164 (50)	
Hauteur maximale entre les unités intérieure et extérieure	pi (m)	100 (30)	100 (30)	50 (15)	50 (15)	

Unité Intérieure: Serpentin en A

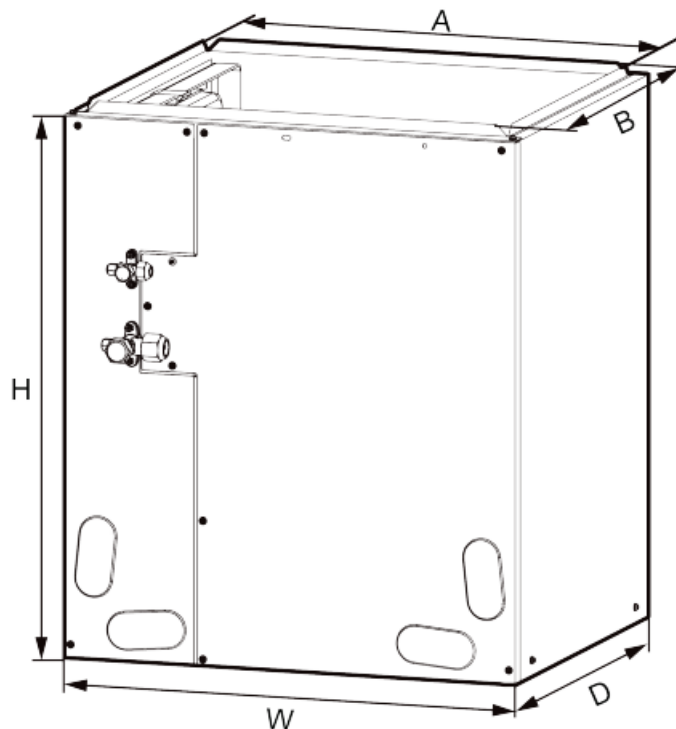

Serpentin en A	W		D		H		A		B	
	po	mm	po	mm	po	mm	po	mm	po	mm
GCAT24F/NAA	17 ½	445	21 1/4	540	23	585	15 7/8	405	19 3/8	492
GCAT36F/NAA										
GCAT48H/NAA	24 ½	622	21 1/4	540	28 ½	725	22 7/8	580	19 3/8	492
GCAT60H/NAA										

Les spécifications sont sujettes à modification sans préavis

Projet:	
Ingénieur conseil	
Entrepreneur électricien:	
Distributeur:	
Date:	
Contact:	
Commentaires:	Approbation Information